

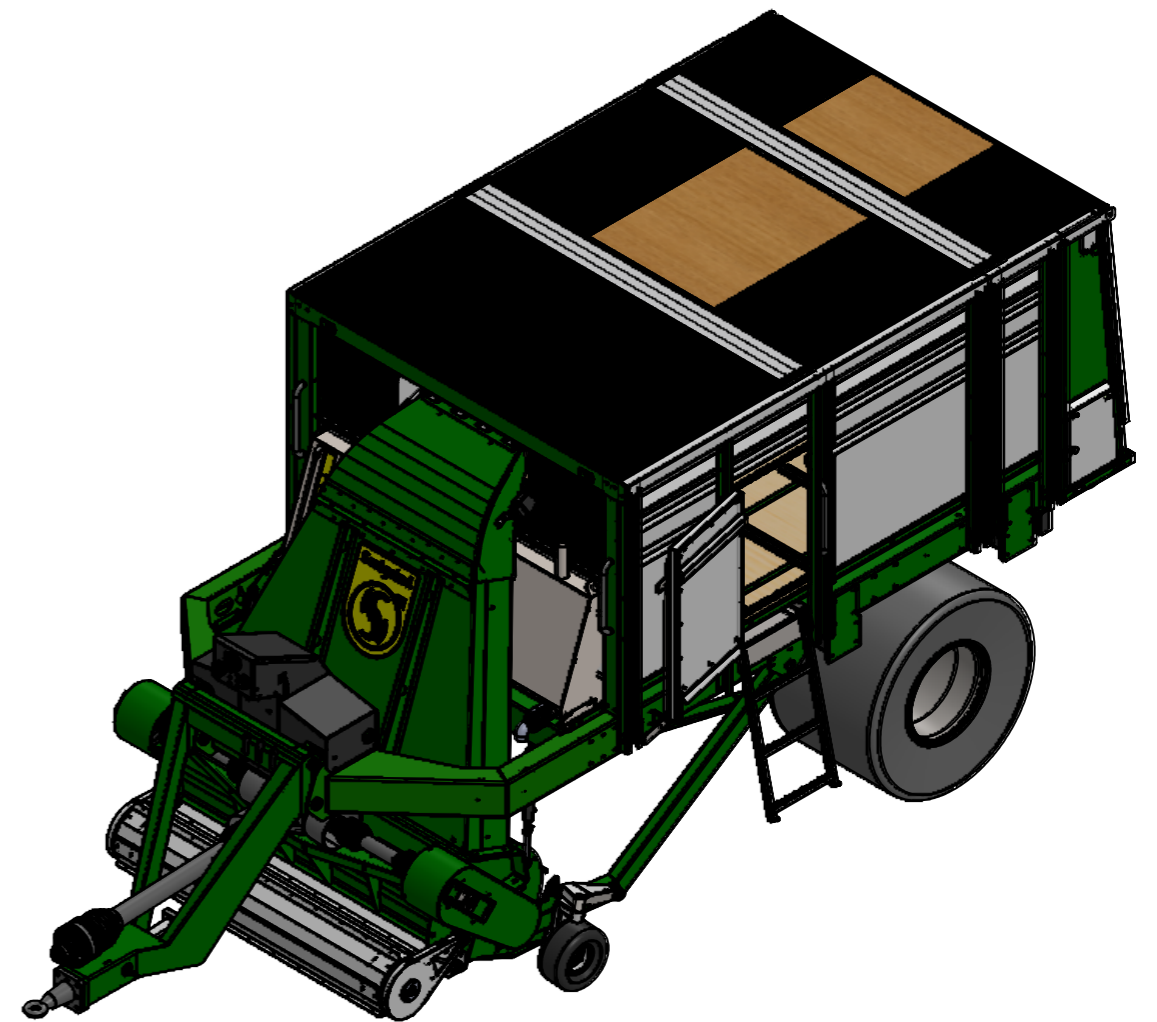

ITEM NO.	PART NUMBER	DESCRIPTION	QTY.
1	32410	Bunramme kort monteret	1
2	31860	Syretank monteret	1
3	31050	Prosesor monteret	1
4	32450	Understell enkelakslet monteret	1
5	32540	Overbygg 13 kubikk	1
6	32970	Drag og ramme monteret	1



Material:		Thickness:	Surface treatment:	
Tolerance not specified according to: NS-EN 1430:2009.		Sheet scale:	Drawing number:	
Designed by: Helge		17.03.2026	1:100	32500
Weight 4.190 Kg		Projection: A3	Revision: T2	
		Fønix Multikutter 13		
		Content in:	Project:	Replaced by:

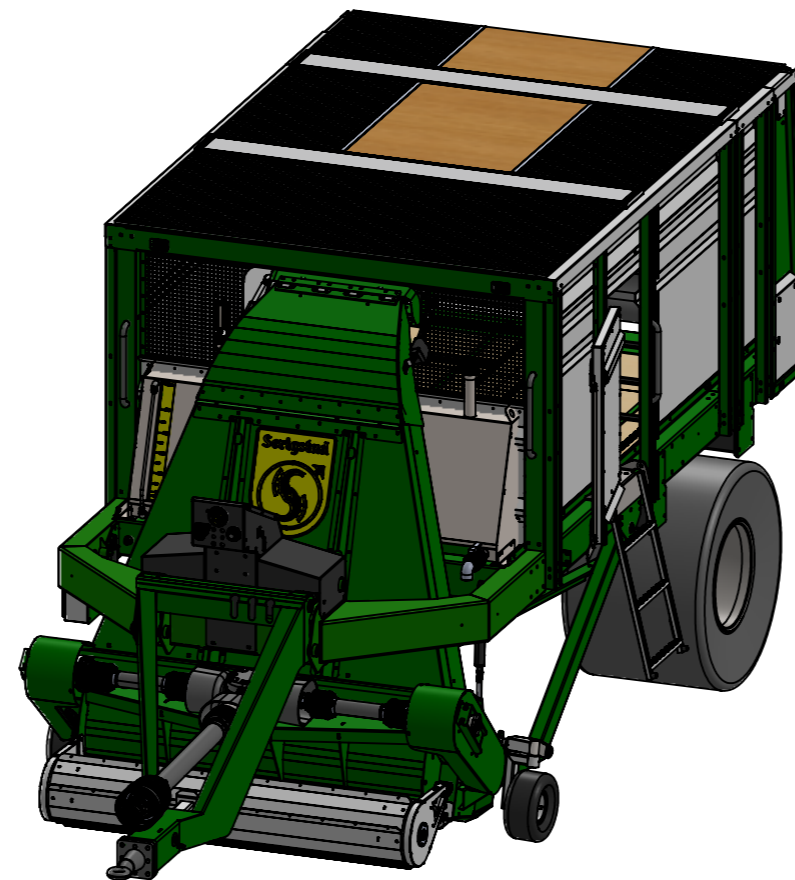
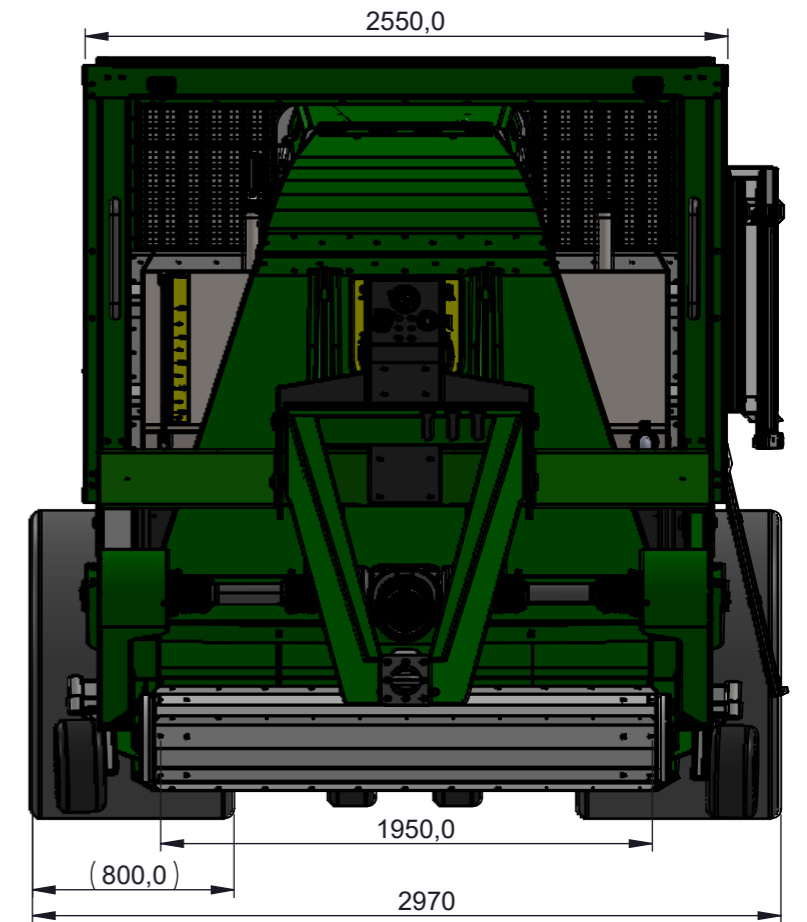
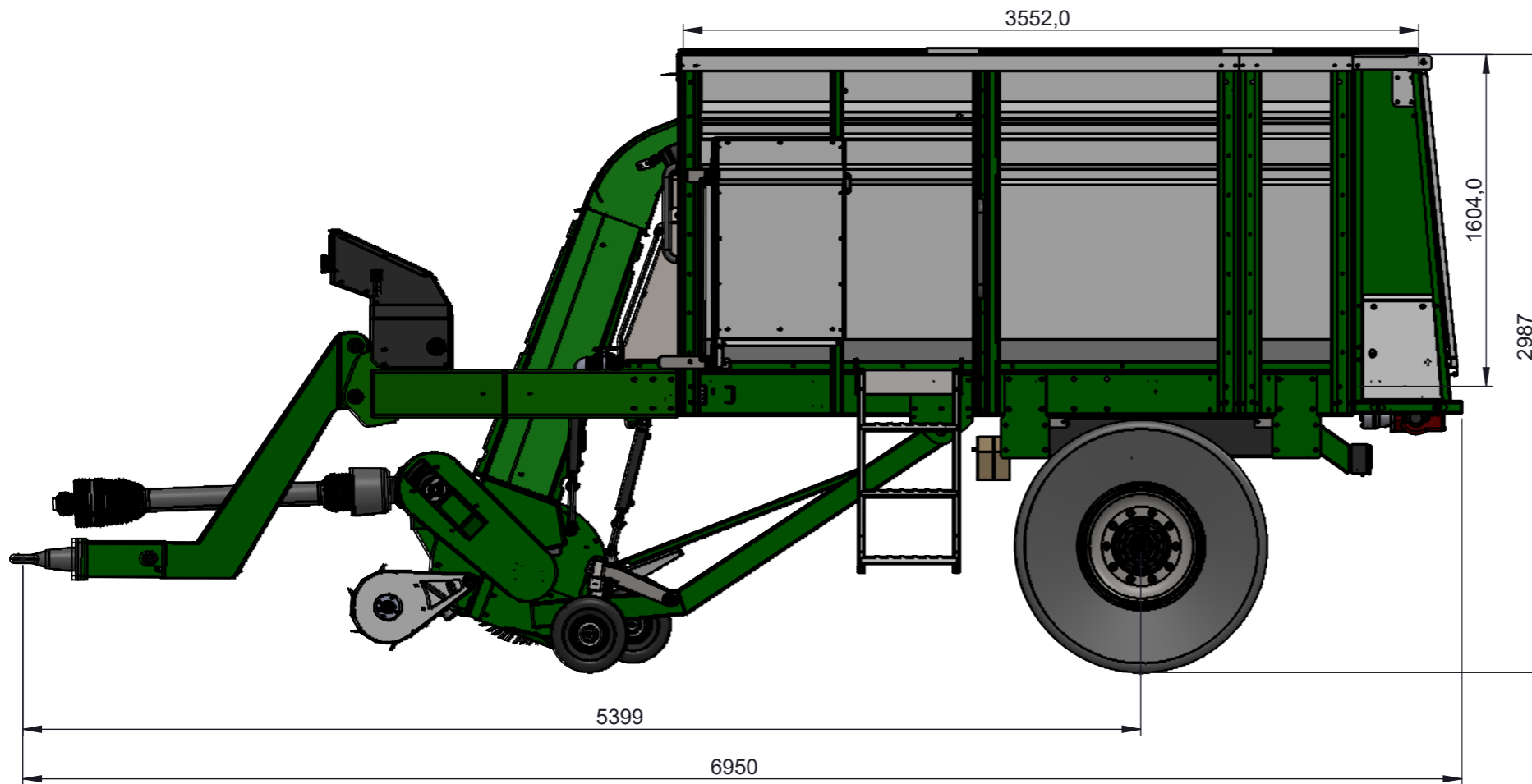

Material:	Thickness:	Surface treatment:	
Tolerance not specified according to: NS-EN 1430:2009.	Sheet scale:	Drawing number:	Revision:
Designed by: Helge	17.03.2026	32500	T2
Weight 4.190 Kg	Projection: A3	Fønix Multikutter 13	
Content in:		Project:	Replaced by:

